



SSCSBAS21/A/C/SS6 Series

Fast Switching Diode

● Features

- ✧ Extremely fast switching speed
- ✧ Surface Mount Package Ideally Suited for Automatic Insertion
- ✧ For General Purpose Switching Applications
- ✧ High Conductance

● PIN configuration

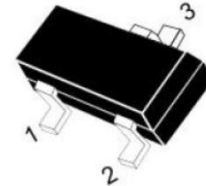

SOT-23

● Applications

- ✧ Ultra high-speed switching
- ✧ Voltage clamping
- ✧ Protection circuits
- ✧ Blocking diodes

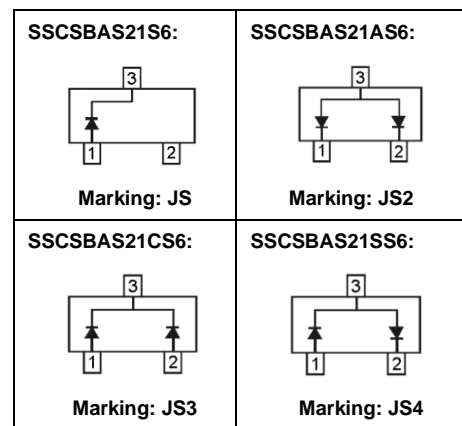

Circuit Diagram

● Absolute maximum rating @T_A=25°C

Parameter	Symbol	Value	Unit
Peak Repetitive Peak Reverse Voltage	V _{RRM}	250	V
Working Peak Reverse Voltage	W _{RWM}	250	V
Reverse Voltage (DC)	V _R	250	V
Forward Continuous Current	I _{FM}	400	mA
Non-repetitive Peak Forward Surge Current @ t=8.3ms	I _{FSM}	2.5	A
Power Dissipation	P _D	225	mW
Thermal Resistance from Junction to Ambient	R _{θJA}	555	°C/W
Junction Temperature	T _J	125	°C
Storage Temperature	T _{STG}	-55 ~ +150	°C



● Electrical Characteristics @T_A=25°C

Parameter	Symbol	Conditions	Min.	Typ.	Max.	Unit
Reverse Voltage	V _R	I _R = 100uA	250			V
Forward Voltage	V _F	I _F = 100mA			1.0	V
		I _F = 200mA			1.25	V
Reverse Current	I _R	V _R = 200V			0.1	uA
Diode Capacitance	C _D	V _R = 0V, f = 1MHz			5	pF
Reverse recovery time	t _{rr}	I _F = I _R = 30mA, R _L = 100Ω, I _{RR} = 0.1I _R			50	ns

● Typical Performance Characteristics

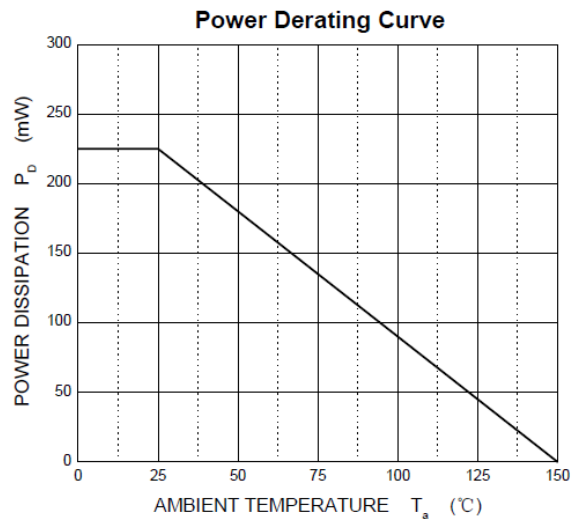
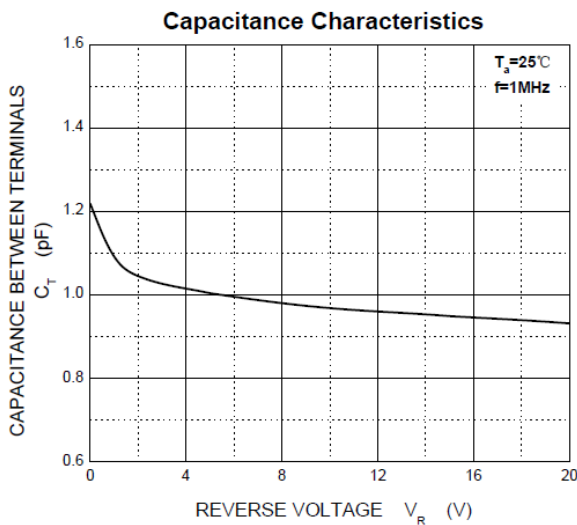
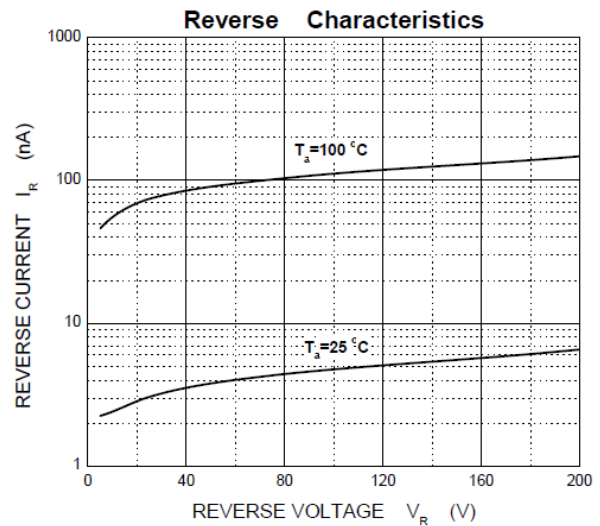
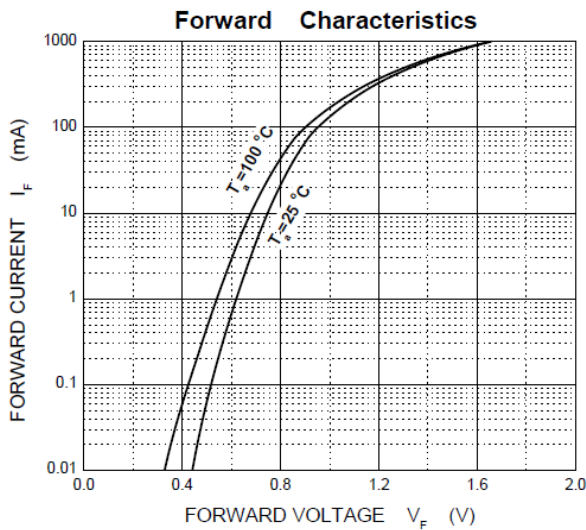



● Package Information

Ordering Information

Device	Package	Marking	Qty per Reel	Reel Size
SSCSBAS21S6	SOT-23	JS	3000	7 Inch
SSCSBAS21AS6	SOT-23	JS2	3000	7 Inch
SSCSBAS21CS6	SOT-23	JS3	3000	7 Inch
SSCSBAS21SS6	SOT-23	JS4	3000	7 Inch

Mechanical Data

Case: SOT-23

Case Material: Molded Plastic. UL Flammability

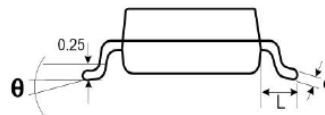
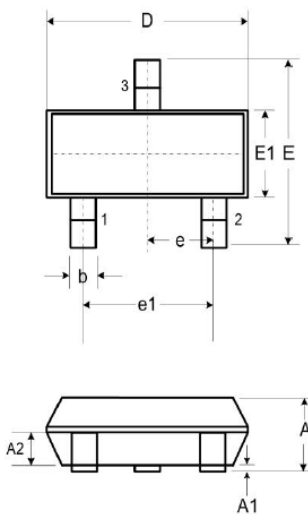

DIM	Millimeters		
	Min.	Typ.	Max.
A	0.89	-	1.12
A1	0.01	-	0.10
A2	0.88	0.95	1.02
b	0.30	-	0.51
c	0.08	-	0.18
D	2.80	2.90	3.04
E	2.10	2.37	2.64
E1	1.20	1.30	1.40
e	0.95		
e1	1.90		
L	0.40	0.50	0.60
L1	0.55		
N	3		
θ	0°	-	8°

Recommended Pad outline

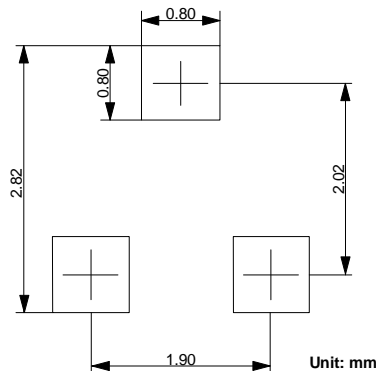



DISCLAIMER

SSCSEMI RESERVES THE RIGHT TO MAKE CHANGES WITHOUT FURTHER NOTICE TO ANY PRODUCTS HEREIN TO IMPROVE RELIABILITY, FUNCTION OR DESIGN. SSCSEMI DOES NOT ASSUME ANY LIABILITY ARISING OUT OF THE APPLICATION OR USE OF ANY PRODUCT OR CIRCUIT DESCRIBED HEREIN; NEITHER DOES IT CONVEY ANY LICIENCE UNDER ITS PATENT RIGHTS, NOR THE RIGHTS OF OTHERS.

THE GRAPHS PROVIDED IN THIS DOCUMENT ARE STATISTICAL SUMMARIES BASED ON A LIMITED NUMBER OF SAMPLES AND ARE PROVIDED FOR INFORMATIONAL PURPOSE ONLY. THE PERFORMANCE CHARACTERISTICS LISTED IN THEM ARE NOT TESTED OR GUARANTEED. IN SOME GRAPHS, THE DATA PRESENTED MAY BE OUTSIDE THE SPECIFIED OPERATING RANGE (E.G. OUTSIDE SPECIFIED POWER SUPPLY RANGE) AND THEREFORE OUTSIDE THE WARRANTED RANGE.

OUR PRODUCT SPECIFICATIONS ARE ONLY VALID IF OBTAINED THROUGH THE COMPANY'S OFFICIAL WEBSITE, CRM SYSTEM, OR OUR SALES PERSONNEL CHANNELS. IF CHANGES OR SPECIAL VERSIONS ARE INVOLVED, THEY MUST BE STAMPED WITH A QUALITY SEAL AND MARKED WITH A SPECIAL VERSION NUMBER TO BE VALID.